



October

Minneapolis, Minnesota U.S.A.

2023

TCRC Scale Saturday Brings Beautiful Planes To Jordan

By Scott Anderson

Saturday September 9th arrived at TCRC's Jordan Model Air Park with cool sunshine and light clouds. Brian Johnson opened up the field at 0730 followed by Scott Anderson at 0800. The event was billed on Facebook and on the TCRCOnLine website as running from 9am-3pm for members and guests to show and fly their radio controlled flying scale models of man carrying aircraft.

We had 14 pilots and as many spectators visit our Jordan field for the event.



Bodhe Sheerer's SR-71 Blackbird soars over the skies of Jordan at TCRC's Scale Saturday. (Photo by Pedro Restrepo)

Here are some of the pilots and planes from the event: Scott Anderson -- 1/4-scale Seagull Models Ryan PT-22 Recruit, Hanger 9 Carbon T-28

Trojan, B-25 electric, F4U Corsair; Brian Johnson – Smith Mini Plane, Spitfire; Ken Weddell – Skybolt Bipe; Blake Dobinger – F4U Corsair, Turbo Timber Evolution, Turbo Timber Evolution UMX; Bodhe Sheerer – Cirrus, SR-71 Blackbird (EDF), Extra 300; David Andersen – 1/4-scale Mitsubishi Bab's, Hanger 9 Carbon T-28; Scott Thompson – Laser; John Madison – L-4 Cub, T-28 Trojan, many more; Matthew and Nason Singsoos – F-15 (EDF), Helicopter; Jacon and Etan Walters – Electric plane; Gregory Hap – Kaos 60; Brian Crossley – Pietenpol, A-10 Warthog (EDF); Roy Maynard – Hanger 9 Carbon T-28 Trojan, Balsa USA 1/4-scale Fokker DR-1; and Joe Neidermayr – Pilitus. Lots of great pilots and airplanes!

After a pilots' meeting at 10am flying progressed to light and variable winds. We were joined by a couple of young families looking for a club to join. Scott was able to provide flight assistance to two pre-teens flying their first RC airplanes later in the day.

Attendance was light compared to previous years due to the number of other events happening the same day as well as the threat of rain. I felt it was worthwhile as we may get 2-4 new members from the experience!

Continued On Page 3, Col. 1

A Note from The Head Wing Nut

By Bob Briesemeister

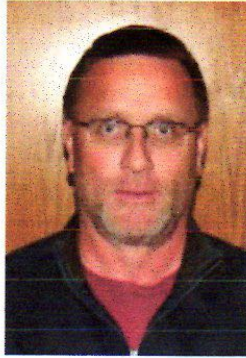

Hello Members,

The calendar says that fall is here but on Sunday October 1st it was 92 degrees, setting a new record. I'm not sure what to think about the weather extremes we are having this year from draughts to flooding, heat waves to record setting snow. I guess that with the high and low temps and drought to flooding rains it creates average temps and precipitation. I vote for getting back to average not extreme.

Yes, it's fall but it's a great time for flying with moderate temps and precipitation. The one thing to keep in mind is when you need to retrieve an airplane you need to wear a vest. The hunters who lease the property to the north of the TCRC flying field have been in the woods for a couple of weeks already. Please be safe!

There are some new members that have joined in the last few weeks taking advantage of the three month free late season sign-up which includes next year. If you see a face or two that you don't recognize please introduce yourself and help them out with any questions they might have.

TCRC has one more flying event on the calendar for 2023. The event is Crocktoberfest which is our season finale on October 7th. There will be food, soda and water available. There will be some competition flying along with the paintball gun to shoot at a flying airplane. If you have any questions, please contact Brian Johnson.

The last meeting at the flying field for 2023 was held in September. We were able to have the meetings from June thru September at the field. It's nice to be outside for the summer meetings and also have a chance to fly on those Tuesdays. At the September meeting the donated estate of Mike Timmerman was available for member's purchase. The planes and larger items were put on a silent auction and the smaller items were available for sale with reasonable offers accepted. The items that did not sell were for sale at the swap meet and what is left will be available at the October membership meeting. I would like to Thank Mike's wife Sherri for donating his airplane estate to the club.

Just a reminder the October 10th membership meeting will be held at Crosspoint Church at 7pm. Please bring an airplane or project for Show

& Tell to the meeting. Also mark your calendar for the Banquet on November 18th.

Good flying!



New Members

TCRC took in three new members in September.

Jackson Zasada lives at 1005 Lavon Lane in Burnsville, 55306. His phone number is 952-200-5114 and his email address is goodluck159@hotmail.com. Jackson is a Junior member and has been flying for a year and one-half. He already has lots of airplanes including a Twin Timber, a T-28 and a Cirrus.

Bodhe Scheerer lives at 5246 13th Avenue in Minneapolis, 55417. His phone number is 612-247-3692 and his email address is bodhescheerer@gmail.com. He has been flying for two years and has many planes to fly.

Gregory Hagen lives at 1680 Skywood Lane in Eagan, 55122. His phone number is 651-331-9519 and his email address is gth1887@gmail.com. Gregory has been flying for two years and has been flying park models.

When you see Jackson, Bohde and Gregory at a meeting or the field, be sure and introduce yourself and welcome them into TCRC.

With these three new members the club now has a membership of 109. 😊



TCRC Scale Saturday

Continued From Page 1

Thanks to Brian Johnson for assisting with the generator and PA system and to David Andersen & Brian Crossley for sharing their experiences with our guests! *Editor's Note: Special thanks to Scott for chairing the event and attracting so many pilots and planes from the Twin Cities area.*

See page 4 of this newsletter for more photos. ☺

Getting Ready For First Flight Of The Day On Scale Saturday



Scott Anderson has help doing a final pre-flight before taking his Ryan PT-12 up at Scale Saturday. (Photo by Pedro Restrepo)

THE TCRC FLARE OUT Monthly Newsletter



****TWIN CITY RADIO CONTROLLERS INC.****

Purpose: To preserve, encourage, and further develop the hobby of building and flying radio controlled model airplanes.

2023 Officers

President	Bob Breisemeister 612-964-8877
Vice President	Chris O'Connor 612-619-5471
Secretary	Ken Weddell 952-500-3446
Treasurer	Tim Wirtz 952-941-5357

TCRC Flare Out

Editor James R. Cook 952-200-2030
Publishers: Pat Dziuk 952-445-3089

Website: <http://www.tcrconline.com>

Warthog Is Sure A Misnomer For Such A Beautiful Aircraft



Brian Crossley's A-10 Warthog glides in for a great landing at Scale Saturday. (Photo by Pedro Restrepo)

Pictures From TCRC's Scale Saturday



A nifty looking Vulcan soars over the TCRC field on Scale Saturday.



Scale Saturday on September 9th saw lots of good looking planes touching down on the runways.



Scott Anderson put in lots of time this past year building his Seagull Model's Ryan PT-12 Recruit and it looked fantastic in the air.



TCRC's Scale Saturday was for young and old alike, in both planes and pilots.



The Spacewalker was graceful in the air and good looking on the ground.



If Joe Neidermayr is at the field you can bet that there will also be a German aircraft there.

Photos by Pedro Restrepo

TCRC Fall Float Fly On A Beautiful Day

by Steve Meyer

On this beautiful September morning I met Chris O'Connor at Bush Lake Park beach. Chris was towing the retrieval boat which we needed to start the event that day. Getting to the boat launch pad we found it to be 20 feet away from the water. Due to the drought this summer the lake water was down two to three feet. Plan B.... With some help we rolled the trailer down the beach and pushed the boat off into the water. Thanks to everyone who helped get the boat in and out of the lake.



The pilots that took advantage of the beautiful weather at the Fall Float Fly on September 16th at Bush Lake. (Photo by Steve Meyer)

The surface of the lake that morning was like glass and Terry Splettstoesser's little Arrow Scout was the first to make a ripple on it. Terry also flew a Tidewater and a Twin Otter. After Terry's flight I had a short pilot's meeting where I went over the rules of flight for the day. After the meeting it was time to fly!

I flew my Timber and ancient Fly Baby. Larry Couture had some bad luck and crashed his LT-40 and lost its engine to a watery grave. Ken Weddell had some problems with his Tidewater, so he became our designated retrieval boat captain. Chris O'Connor flew his Flyzone Beaver and E-flite Maule. Brian S. represented the Coast Guard with his Red and White Avios Albatross flying boat. Dave Mansfield also brought an HU-16 Albatross, a Piper Cub and two other planes. David O'Hara flew two very unusual aircraft, a gray Northstar and a silver and red Drake II. Two Super Cubs were flown by Darryl Volk and Thaddeus Gorycki. Thaddeus also had an E-flite Air Tractor on floats. This year we had 16 pilots flying over 25 aircraft at the event.

We had a special spectator at the event, 100-year-old WWII veteran Lester Schrenk. Lester was the ball turret gunner on a B-17 flying fortress. He said he saw lots of action flying over Europe. On his 10th mission he had to parachute out when his plane was shot down. He spent over a year in different German POW camps. We all thanked him for his service and for his stories. He was able to fly Thaddeus' Super Cub, with the help of a buddy box.

Thanks to Mark Wolf for the use of his boat and to Chris O'Connor, for getting the boat to the lake. Hope to see you all at the lake next spring.

More Float Fly pix can be seen on page 6 and 11 of this newsletter. ☺

Calendar

- | | |
|---------|---|
| Oct. 7 | Crocktoberfest
Season Finale
Jordan Field
Brian Johnson |
| Oct. 10 | TCRC Membership
Meeting, 7:00 PM
CrossPoint Church
Bloomington, MN |
| Nov. 7 | TCRC Membership
Meeting, 7:00 PM
CrossPoint Church
Bloomington, MN |
| Nov. 7 | TCRC Elections
CrossPoint Church
Bloomington, MN |
| Nov. 7 | Ugly Airplane Contest
CrossPoint Church
Bloomington, MN |
| Nov. 18 | TCRC Annual
Banquet 5 PM
David Fong's
Restaurant
Prior Lake |

Pictures From TCRC's Fall Float Fly September 16



What would a float fly be without a Big Stik gliding above the water?



The retrieval boat was powered with an Armstrong engine.



The Fall Float Fly has been hosted by Steve Meyer for many years, and he always makes sure to get in lots of flights over the water.



Sherwood Heggen hasn't missed very many float flies over the years, and he always has a classic plane for the flights.



Terry Splettrstoeser's Arrow Scout enjoyed the water almost as much as Terry.



Chris O'Connor puts lots of great flights in on his De Havilland Beaver.

TCRC Jordan Flying Site Approved As FRIA By FAA



Congratulations!

The flying site located at/near 18266 West Sioux Vista Drive that you submitted on behalf of Twin City Radio Controllers has been approved as a FAA Recognized Identification Area (FRIA). This designation will satisfy the remote ID requirement for anyone flying at your club's site beginning September 16, 2023.

The email you received from the FAA DroneZone serves as your official notification. Please keep a copy of this for your records. If you did not see the email in your inbox, please check your email's SPAM folder. If you accidentally deleted it, please contact us at Fria@modelaircraft.org and we can resend the email. Please allow for some extra time, as we are still busy submitting applications on behalf of other clubs.

Please disregard the link at the bottom of the FAA email notification. This link will only work for the AMA team member who submitted the application on your behalf.

Your FRIA will be in effect until 09/05/2027, and AMA will request renewal for this location when possible. In the meantime, please contact AMA at Fria@modelaircraft.org with any FRIA related questions.

Sincerely,

AMA Clubs Department



TCRC Elections November 7th

It is already October and the year is racing past. That means that the TCRC elections are only one month away. As usual, the elections will be held at the November meeting, which this year will be Tuesday, November 7th at CrossPoint Church.

All four of the officer positions are up for election this year plus one of the three at-large board seats. The board seat held by Gerry Dunne is not up for election this year. The board seats held by Brian Johnson and Jim Ronhovde are up for election this year.

Currently the officer positions are held by Bob Breisemeister, president; Chris O'Connor, vice president; Ken Weddell, secretary; and Tim Wirtz, treasurer.

As of this time, the editor is not aware of any incumbents or nominees being proposed for election.

The elections will be discussed at the October 10th membership meeting. Please consider being a candidate for TCRC office. The club needs you. Be both a voter and a candidate at the TCRC elections on November 7th. ☺

Never Forget How Dangerous Props Are!

by Steve Flaten

Yesterday I went to the field to get in some flights after being away from flying for about 12 years. Thought I had a good background in the right procedures and experience but went back to a trainer instead of the turbine, ducted fans and aerobatic planes where I ended those years ago.

I met with Thad Goryki and Dave Erickson, got in a couple flights with Thad, which went well. Next, I unpacked my old glow fuel trainer and fired it up for more flights, went to full throttle and reached over to set the fuel needle valve. Problem with this was I was standing in front of the plane, versus standing beside and behind the plane. This brought my fingers right into the spinning prop.



Moral of the story was no matter how much you have flown, keep the basic rules in mind and mentally work through each step and checklist before you move on.

Safety At The Field

By Larry Couture

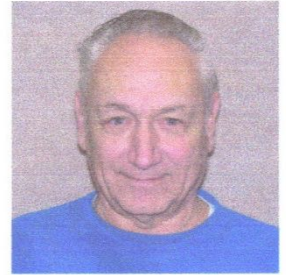

The weather has been very hot and when at the field make sure that you keep yourself hydrated. That is about to change and you will need warmer coats and sweaters but make sure there are no strings or ties that dangle as a propeller can take that and wind it up instantly and choke you.

We did have a bad mistake the other day when an older pilot had some trouble starting an engine, but when it started he put his hand through the running prop to adjust the engine and the result was 25 stiches and a lost finger nail. THAT WAS LUCKY. He could have lost a finger or two. I know that this is easy to do but always be sure you're behind the engine before you try to adjust it.

Another thing to watch out for is in battery life or condition, so always make sure they are charged and have not set for long time as that can be a problem and it may be that they have to be replaced.

I want you all to talk to all other pilots that are flying with you so that you each know what the other maybe doing or going to do such as landing, touch-and-go, going around again and all other things that can avoid an accident.

Remember to wear a vest when going into the woods and make sure others know you're out there so they can help you if you get lost or confused. This does happen!!

When you are flying have a great time and keep the rubber side down and all landings from which you can fly again are great but not always graceful. 😊

Safety Always Comes First!

Wanted to thank Thad and Dave for getting my fingers all taped up and loading up my gear so my wife could take me to the ER. That was really great help for a guy they hardly knew, and I appreciated their help and caring.

Result was about 25 stitches on the pinky and ring finger, losing the nail and damaging nail bed on index finger and gluing some tears on nail bed and the middle finger. I got lucky as it could have been a lot worse. 😊

Hall XFH-1

by Conrad Naegele

The September Mystery Plane was the Hall XFH-1.



Designed by Charles Hall of the Hall Aluminum Company, this plane featured a light aluminum airframe with fabric covered ailerons and tailfeathers. It had a watertight fuse that would float due to a water landing. Also the undercarriage was jettisonable, to prevent a nose over.

It did include a stressed-skin semi-monocoque fuse, unusual in the 20's. The prototype was presented for flight testing in June 1929. However, it showed poor control response, was quite tail heavy, and the upper wing revealed rather extensive structural weakness. All defects were repaired, but the Navy was not impressed, and no contract followed. The number of prototypes is not known for sure, but records show that three were presented.

The Hall XFH had a wingspan of 32-feet, a weight of 2,414 pounds, a speed of 153 mph, and a range of 275 miles. It was powered by a Pratt and Whitney R1340 9-cylinder radial engine that developed 450 horsepower. ☺

Annual Ugly Airplane Contest

by Sherwood Heggen

This is the time of year when all active fliers should be thinking about one thing: which airplane to enter in the Ugly Airplane Contest at the TCRC membership meeting on November 7, 2023. Don't take this lightly. There is a valuable gift certificate and a traveling trophy that gets upgraded most every year by the previous winner.

Qualification is simple. The airplane has to be flyable and look used. Everything from well used to holding together for one more flight is welcome.

Bring what you have. Enjoy the honor of owning ugly. Let's see your stuff! ☺

Always Wear An Orange Vest To Retrieve A Plane

Hunting season has started in Minnesota, and it is a club requirement to wear an orange vest if you go into the woods.

If your airplane does go down in the woods, the orange vests are quite close. The orange vests are stored in the rafters of the shelter and easy to reach.

Be safe! Wear an orange vest anytime you have to retrieve an airplane. ☺

MNBigBirds.com Free! Scale Plan Downloads

Andersen Designs

New! Hawker Hurricane Mk II 1/4 Scale British Fighter

New! Howard Pete 1/3 Scale Racer

New! KI-45 DRAGON SLAYER

Add'l Extras

- In Flight Videos
- Construction Articles
- Scale Documentation
- Paint Masks & More!

Composite Parts Available Thru MACKO

FAA Extends Remote ID Enforcement By Six Months



As AMA anticipated, The FAA has announced they are extending the Remote ID enforcement date by six months. Operators now have until March 16, 2024 before they will have to comply with the rule. This extension provides the FAA more time to approve FRIA applications and manufacturers the time for production of broadcast modules. For the FAA’s full statement on the extension, go to faa.gov.

To remain current with the most recent government-related news, regularly visit the [AMA Government Affairs blog](#).

Sincerely,

AMA Government Affairs Team

Show & Tell Data Form

Bringing a plane to the TCRC meeting for Show & Tell?

If you are, be sure to go to the club website TCRCOnline.com and print out a blank Show & Tell Data Form. Fill this out and make sure it gets to the newsletter editor, Jim Cook so that the correct information shows up about your new airplane in the newsletter.

Also, if Jim is not at the meeting, make sure someone takes a picture of your new masterpiece and emails the picture to Jim also. If he is not at the meeting, you can have someone take a picture of the completed form and email that picture to him also. 😊

TCRC meets every month on the 2nd Tuesday at 7:00 PM in Fellowship Hall of CrossPoint Church located on the southeastern corner of the intersection of 98th Street and France Avenue in Bloomington. Guests are welcome to attend these meetings.



October Mystery Plane

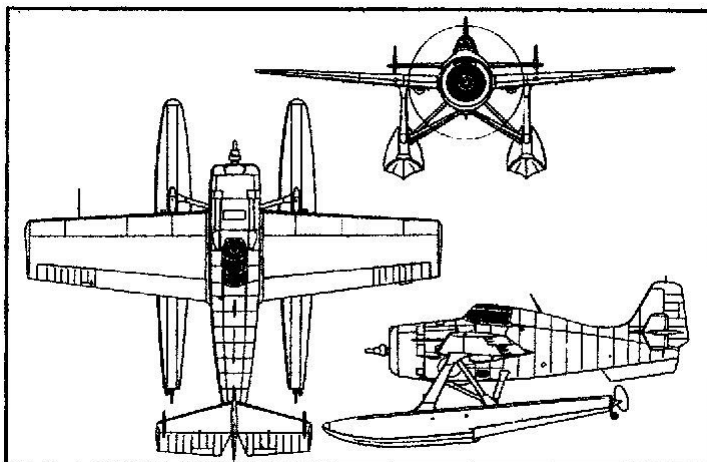

Back To CrossPoint Church

Just a reminder. We have spent the entire summer with our meetings-at-the-field every month, enjoying some great weather and doing what we love to do – flying R/C airplanes.

But summer is over. Henceforth, the TCRC meetings will be back to their normal location at CrossPoint Church in Bloomington. 😊

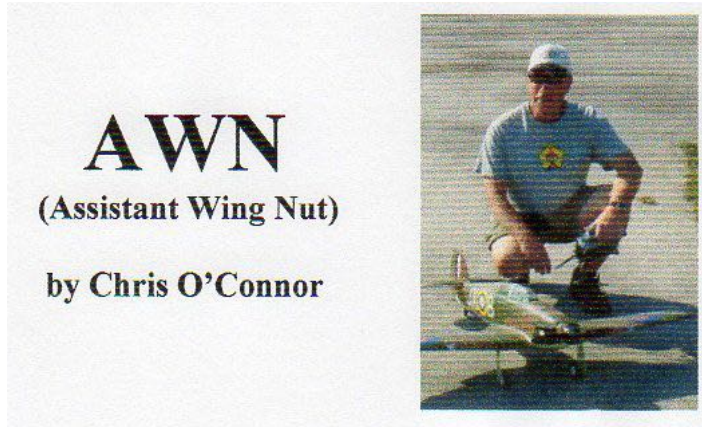

Here it is a beautiful fall day that feels like July with heat and humidity. Oh well keep flying anyway.

Remember for most of us the flying season is winding down. So, time to think about getting our equipment and planes ready for storage. Starting with batteries, especially the Lipo's varieties. The worst thing you can do is leave your Lipo's fully charged. That can shorten the useful life of them and cause the puffing that we see in so many of them. So, putting them in a storage charge of 3.8 volts is the best and also the safest way to keep them stored for the winter. If you get new ones from the hobby store or online that's the voltage they have when shipped. Remember to store in a cool place and use those Lipo's bags to keep them in.

Taking care of batteries goes a long way to successfully maintaining our models. Also, this is a good time to go thru our models and see how they are holding up from all that summer flying, and fix anything that's broken.

Remember to leave yourself some models to use this fall. We still have some great days for flying, and Brian's Crocktoberfest to participate in. I know he has some fun events planned for the day.

This is also the time to think about new models that we could get going over the winter. Is there that special one you always wanted to have? Now's the time to think about getting started on it. So many types to choose from such as warbirds, sport, pattern, scale, edf jets, gliders, etc. These come in the form of foam, ARF's, plans, and yes even kits. You can also use a kit cutter and have your own form of a kit. If building is not your way maybe kit bashing an ARF or repainting a foam plane to your style and making a one-of-a-kind is your dream. So many possibilities, use your imagination.

Let's see as many of you as possible flying this fall while the weather is still good! ☺

TCRCOnline.com

More Pix From The Fall Float Fly



Pictures From TCRC's Fall Swap Meet



The layout for the Fall Swap Meet at the Jordan field was pretty



I don't know if I would buy a used car from this guy, but maybe an airplane.



Sellers at the TCRC Swap Meet are well prepared to get planes to and from the event.



There were sellers with a lot of R/C stuff, and some with just a plane or so at the swap meet.



It was a great day to be at the field for both the swap meet and for some flying.



After buying something at the swap meet, you just had to walk across the area to your car.

Twin City Radio Controllers



HOBBY

HOBBY ZONE
EST. 1979

Check us out! 952-941-1866
info@hobbyzone.com

7171 Shady Oak Road
Eden Prairie, MN 55344

Monday - Friday 10AM - 5:30PM
Saturday 10AM - 4PM
Sunday Closed

Most in-store prices are 5% - 10% OFF
online prices. Plus, every month we
select two popular items at 15% OFF!

www.hobbyzone.com

ZONE

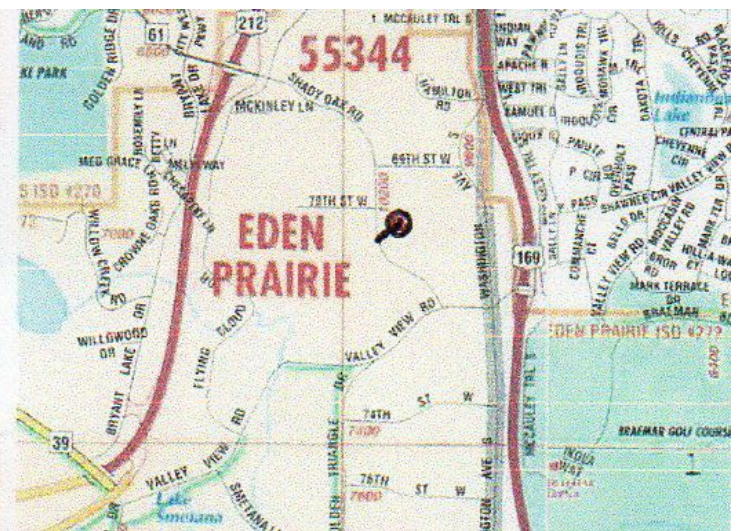

BIG SKY HOBBY™
Great products, expert advice.

Open Monday thru Saturday, 10 am - 6 pm
Have Special Orders or Questions?
Contact: Jeremy@BigSkyHobby.com

