



September

Minneapolis, Minnesota U.S.A.

2014

Model Aviation Day 2014

by Scott Anderson

The word went out via e-mail, FaceBook and posters in the hobby shops that TCRC was holding their 15th Annual Model Aviation Day (MAD2014) Saturday, August 23rd, and the people came to participate! Near noon, I counted over 55 members and guests.



Butch Neutgens and Mike Bellefuele talking in front of the Simulator Tent. (Photo by Scott Anderson)

The weather threatened but we only received a slight sprinkle near noon. The rest of the day was overcast but with a fresh breeze from the east.

Pilots brought all kinds of models representing our hobby. Electrics were the most numerous, followed by nitro-powered planes and a handful of larger gas-powered models.

Mr. Enthusiasm, Tim Wirtz, managed the Flare-Out Café, the Flight Simulator, and a trainer on a buddy box. He gave introductory flights to several guests and potential new members including Sandy Meyer, Steve Meyer's effervescent spouse! Sandy had been teasing that Steve would not let her fly his Super Cub so we put her up on Tim's trainer.

Shawn Dwyer was the 'Concessioneer Extraordinaire', keeping the crowd supplied with food and beverage all day.

Steve did give some terrific flight demonstrations with his G26 powered Super Cub showing its aerobatic qualities as well as its low speed capabilities. Every landing was as smooth as could be!

Tom Carlson also did some flight instruction with Bill John and actually had Bill perform his first landing! It was exciting to see.

We had a family join us again this year with their 3 boys and grandpa who happened to be a Korean War F-86 pilot. He had a terrific time talking to members and sharing his experiences. At one point he said that he had not had so much fun since his last pilots' briefing!

Continued On Page 3, Col. 1

A Note from The Head Wing Nut

By Bob Briesemeister

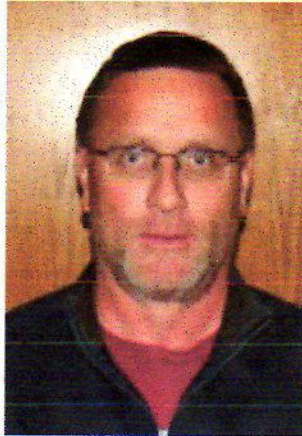

Hello Members,

It's hard to believe that summer is coming to an end. With the shortened flying season due to the wet weather, it really has flown by...no pun intended. In the last month we have fortunately had some good flying weather and let's hope it continues into the fall. I think that flying in the fall is always nice with the cooler temps.

"If we feed them they will come!" If you were not able to attend the August membership meeting it was held at the field. There were 30 to 35 people in attendance with a few new faces. Members started showing up at about 2:00 PM to do some flying and the grills were ignited by 5:00. We had a great meal and I want to give a big thanks to Jim Lundquist for grilling so that I was able to get ready for the business part of the meeting. There was a 1/2-hour meeting and then pilots flew 'til dark. I received good feedback from the membership that this meeting venue was fun and different and we should try to do it again next season. There is now a permanent grille at the field for all to use. Remember to turn off the propane and keep it and the area clean.

We were finally able to have a flying event at the field. MAD was held on August 23rd. I want to thank Scott Anderson for pulling this event together. Pilot turnout was good with seasoned pilots providing guests a chance to fly on buddy boxes.

Our next event is the Scale Fly on September 20th. Scott Andersen will again be running this event. If you have any questions on what type of plane can qualify as scale, contact Scott.

The Fall Float Fly will be held at Bush Lake Beach on October 4th from 10:00 a.m. to 2:00 p.m. If you have any questions, contact Steve Meyer.

In the next few weeks we will be installing a flag pole at the field with a solar light on the top. This will be a Memorial Flag to remember the members who have donated airplane estates to TCRC. I will need the help of the membership to let me who has donated their airplane

collection over the years. When I have a list of names I will have a plaque made in their honor, allowing more names to be added over the years. The plan is to mount the plaque in the field shelter. Please email me names of the members you know who have donated and should have their name printed on the plaque. Please ensure when sending the names, they are spelled correctly. Thanks!

Swap meets dates are fast approaching. **Hobby Warehouse** will be on September 13th and **Big Sky Hobby** will be on September 21st. Hope to see you there.

We have had eight raffle drawings for an airplane with eight different winners. With the float fly coming up the plane up for grabs at the September meeting will be a Flyzone DHC-2 Beaver. It has floats and conventional landing gear and retails at \$190.00. So come to the meeting and try your luck! Chances are only \$5 apiece.

Happy Flying!

J

TCRC meets every month on the 2nd Tuesday at 7:00 PM in Fellowship Hall of CrossPoint Church located on the southeastern corner of the intersection of 98th Street and France Avenue in Bloomington. Guests are welcome to attend these meetings.

TCRCOnline.com

Use It!

MAD 2014

Continued From Page 1

Everyone here knew what he was talking about! The boys flew the simulators and the trainers. I hope we might have them join us in a year or two.

Bob Glass flew his G62 powered 'Big One' over and over again giving terrific flight demonstrations. To add to the excitement, Bob was able to make several drops of his teddy bear on a parachute over the field. Terry Splettstoesz of the Crow River RC club demonstrating his athletic skills in running after and catching the bear after each release.

I did some announcing and provided some WW2 background music for the event. I did get a little time to fly my F9F Panther (EDF) and demonstrate lowest possible passes (skip & go's) as well as take up my red-tail P-51 for some giant scale fly-bys and passes.

Member Chris McLaren had several scale electric foam warbirds that he had airbrushed to make them look unique and weathered. Chris will be available to demonstrate the techniques in a future club meeting!

Tom and Loren Temple set up camp and brought a fleet of aircraft. Seventeen year old Loren was constantly in the air with one of his great looking planes.

Doug Elyea was kind enough to bring a 5KW generator that provided all the power we needed for the event. Thank you Doug!

Continued On Page 4, Col. 1

Hands-On Flying Via Buddy Box Was Very Popular



John Bertelsen gets some flight training from Tim Wirtz & pointers from Terry Splettstoesz (CRRC) (Photo by Scott Anderson)

Every Guest Was Eager To Learn All About R/C



Morgan Larson greeted every guest and shared his years of R/C knowledge. (Photo by Scott Anderson)

MAD 2014

Continued From Page 3

I want to apologize to all that participated that I have not acknowledged. You made this event fun!

Next year we'd like to increase the visibility and set up more hands-on stations for new people to see how we create and fly our aircraft. I would appreciate your suggestions on how we can improve the event! Send me an e-mail with your suggestions! J

Calendar

- Sept. 9 TCRC Membership Meeting, 7:00 PM
CrossPoint Church
Bloomington
- Sept. 13 Hobby Warehouse Swap Meet
- Sept. 20 Sky Hobbies Swap Meet
- Sept. 19-21 Scale Fly-In & Camp Out
TCRC's Model Air Park
Jordan, MN
Scott Anderson, Chair
- Oct. 4 Fall Float Fly 10 AM
Bush Lake Park
Bloomington, MN
Steve Meyer, Chair
- Oct. 11 TCRC Season Finale
TCRC's Model Air Park
Bob Breisemeister

The Flare Out Café Was Popular With Young And Old!



Younger guests enjoying the cuisine being served in the Flare-Out Café. (Photo by Scott Anderson)

The Flights Of The Bigbirds Were Crowd Pleasers



Bob Glass gets ready to taxi his 'Big Stuff' out for another flight. (Photo by Scott Anderson)

Pictures From Model Aviation Day 2014



Tom Carlson with a very happy Bill John after his first ever landing.



Sandy Meyer after his very successful training flight with Tim Wirtz.



Safety Officer Larry Couture explains the safety aspects of our hobby to a couple of guests.



Tim Wirtz explains how the transmitter controls the airplane while it is in the air.



Stan Erickson and Steve Meyer help fellow TCRC'er Pedro Restrepo tune his plane.



The pits were full of planes and pilots all day at TCRC's Model Aviation Day.

Wingman

by VP Mike Robin

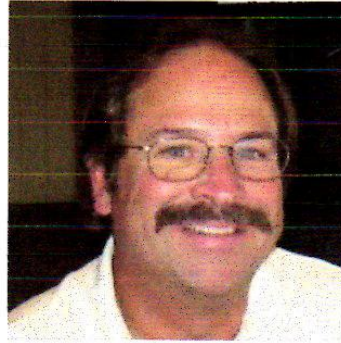

Hello Everyone,

TCRC members were really active by attending a number of area flying events in August. On August 8-10, the Northern Alliance Military Fly In was held at the SMMAC field in Owatonna. Many of our members were participants at the event by either helping to run it or by flying their war birds. Some were just there to learn something new by watching while also enjoying the action-packed weekend.

Just a few days later on August 12th, TCRC held our monthly membership meeting at the Jordon Airpark with a large turnout of members. It was a perfect day with many airplanes flying before and after the meeting. It was nice to see some members that typically do not attend our meetings. Plus we had a nice meal served prior to the meeting.

Then on August 14-17, some TCRC members headed to the War Birds & Classics over the Midwest event held in Fond du Lac, Wisconsin. Anyone who attends both of these 3-day events on successive weekends can claim to be a very serious RC hobbyist!

On August 27th a group of TCRC members headed over to the Scott County Government Center with their airplanes to show support for a public flying site in Cleary Lake Park. Over 80 modelers from a variety of clubs were there, and after much discussion, the Park Commission voted unanimously 6 to 0 in favor of allowing a model airplane field to be established at the park. However, the field is not a sure thing yet, as the Three Rivers Park District Board of Commissioners has yet to grant approval.

A special thanks to TCRC members Joe Niedermayr, Pete Stapleton, and Brian Brastad for all of their hard work and time and effort planning, meeting, and demonstrating our hobby to the Scott County Park Board. TCRC members also went up to the podium to explain to the Commissioners why our area parks need a model airplane field.

September is a fun month because of the swap meets starting with Hobby Warehouse on September 13th, rain date September 20th, and Sky Hobby's on September 21st. If you haven't been to either of these swap meets before, it is well worth your time to check them out. Bring a few RC related unused items to sell, and lots of money to take advantage of some really great deals!

Don't forget to get something ready to fly for the TCRC Scale Fly In and Campout on September 19-21st; otherwise just come out for a fun weekend!

Now for some TCRC business: As your Vice President for 2014, it has been a pleasure to work for you. I have brought many issues from members to the board meetings and have seen positive results due to club members input and requests. Unfortunately, I cannot run for Vice President for the next year due to a very busy schedule.

I would like to see members that have an interest in running for office step up and take a shot at it. It is healthy for our club to have new people in the officer's positions. If you want to be an officer throw your hat in the ring. Pick a position you have interest in, contact the Board, and we will help you get your message to the members so they can vote for you at the November 11th Election Meeting.

If you would like to write something about yourself and why you want the position and what you will do for the club, we will publish it in the October newsletter. If you choose, you can inform the members at any meeting, including the Election meeting, of your intention to run for office.

I will be encouraging all of the current officers that decide to run for reelection to announce their candidacy in the October newsletter.

My program at the next membership meeting on September 9th will be: 'What do the TCRC Officers Do?' **J**

Cleary Lake R/C Flying Project

by Joe Neidermayr

In a heartening show of support and solidarity a 70-plus group of model airplane enthusiasts assembled the evening of August 27 at the Scott County Government Center in Shakopee. They brought their models and displayed them in front of the building making the lawn look like a colorful flowerbed.

The supporters came from many places; some had no club affiliation. Others were from TCRC, MVRC, TriValleyRC, MARCEE, and Grass Field RC clubs.

Also reporters from Shakopee Valley News and the Minneapolis STAR/TRIBUNE came. The reporter from the STAR/TRIB recorded everything and stayed to observe the Scott County commission meeting.

The purpose of this effort is to create flying fields on taxpayer-owned park land like it is being done for other recreations and sports.

Previously an unused meadow in Cleary Lake Park north of CR 68 (190th St.) was identified as a potential site. An investment proposal was submitted based on the resources of MVRC. Two demonstrations to show model airplanes and flying to the park staff and the commission where

conducted during the spring and summer. The money from MVRC club would pay for all the costs to make the field and taxpayer would not have any additional expense.

Cleary Lake Park is a Scott County park but is supposedly owned by the Three River Park District of Hennepin County. To govern parks every county has elected / appointed commissioners for each district in the county, - 7 commissioners in most cases.

At 6:00 P.M. the Scott County Parks Advisory Commission meeting started and item 6a of the agenda was to decide on the proposal requesting the flying field in Cleary Lake Park.

Speaking first at this agenda item Tom McDowell for Hennepin County Three River Park District told the meeting that the unidentified Senior Management Group (SMG) rejected model airplanes in their park system, as it did not align with their interpretation of the parks mission. In the questioning by the Scott County Commissioners it became evident that some of the Three Rivers specific objections were not supported by facts and that in other cases they choose to interpret the parks mission inconsistently. It appears that if they adhere to one interpretation of policy they needed to eliminate many existing activities. However if they could justify those activities then the model airplanes would also fit.

After Mr. McDowell presentation many of the modelers also spoke up and added their views and opinions.

One could see the Scott County Commission was swayed and impressed by the strong showing of the modelers and the good rational put forward.

The commission then unanimously voted for the proposal of the flying field in Cleary Lake Park.

This creates the following situation:

Cleary Lake is a park in Scott County and the Scott County Commission voted for the airfield in their county's park.

Hennepin County Three Rivers Park District owns the park.

Some unknown individuals in Three Rivers management use inconsistent arguments to oppose model airplanes.

The policy of the Three Rivers system is flawed and therefore cannot be uniformly applied.

Hennepin County has commissioners for every one of its districts but it is not clear how the interests of Scott County are represented in the Three River political system.

A very big thank you to all of the people who took the time to come down to the Scott County Government Center and show such great support for our hobby. J

Scale Fly In & Camp Out

September 19 -- 21

August Membership Meeting At The Field

by Jim Cook

The August 12th regular membership meeting was held at the Jordan Model Air Park.



President Bob presides over the 'Meeting at the Field' on August 12th. (Photo by Jim Cook)

Members started showing up around 2:00 in the afternoon, and by 7:00 PM when president Bob called the meeting to order the parking lot was full.



Parking spots were hard to come by during the 'Meeting at the Field'. (Photo by Jim Cook)

The day was bright and sunny with no clouds and it made for some great flying all afternoon. The members brought lots of planes, big and small, and the sky was full of airplanes until about 5:00 PM when Jim Lundquist fired up the grill. The menu included brats and dogs, with chips and when the aroma from the fire reached the piloting stations, planes landed pretty quickly and the pilots headed for the shelter.



The shelter filled up when Jim Lundquist rang the dinner bell. (Photo by Jim Cook)

After the short business meeting, it was adjourned and everyone headed back to the pits for more flying.



The piloting stations were kept pretty full after the meeting. (Photo by Jim Cook)

Flying continued right up until dusk and then it was time to pack it up and head for home.



As the sun started to set in the west, the pits were still pretty active. (Photo by Jim Cook)

All agreed the meeting at the field was a great event and president Bob assured everyone it will be done again next year. J

Warbirds And Classics Over The Midwest 2014

by Scott Anderson

This event held in Fond Du Lac, Wisconsin is one of the seven Warbirds & Classics Alliance events that take place each summer. The goal is to provide a world class exhibition and flying experience for giant scale warbird and classic (civilian aircraft prior to 1964) aviation enthusiasts. It is possible to spend a different weekend at each event over the summer before going home for the building season!



This 20 year old B-17 is powered by (4) Evolution .61 glow engines and it sounds like an electric! (Photo by Scott Anderson)

This was the 5th year for the Fond Du Lac event, hosted by the Fond du Lac Aeromodelers Association (FDLAA) and has been known as 'Fondy' or 'FDL'. The 2014 count was near 180 pilots and over 400 aircraft including the large contingent brought in by the Minnesota Delegation (mostly SMMAC members).

TCRC was represented by Chris and Nathan O'Connor, Steve Meyer, Mark Wolf, and Scott Anderson. Nate and Mark Wolf had driven to FDL immediately after the conclusion of the NAMFI (Northern Alliance Military Fly In) in Owatonna the previous weekend and set up on Monday.

Steve Meyer and Nate O'Connor were both flying new kit-bashed Top Flight P-47D's finished in Flite-Metal and powered by Sach's 4.2's (70 cc) gas engines. They were spectacular to see fly! Scott Anderson and Steve Meyer flew the 'Dawn Patrol' and the WWI gaggles with their

¼ scale Zenoah G26 powered Balsa USA Fokker Dr1's. Steve also brought his electric giant scale Hangar 9 Tiger Moth that he had won in the FDL-2013 Pilots Drawing.

Chris O'Connor and Mark were flying their T-34's. Chris's Frankel T-34 is powered by a Zenoah GT-80 twin and is every bit as fast as any of the fighter I saw. It performed flawlessly.



Carl Bachhuber's Electra on take-off. (Photo by Scott Anderson)

Jeff Quesenbury, Shane (Opie) Logan (both of the Owatonna SMMAC) and Carl Bachhuber flew the three giant transports that Carl had built over the years.

The Horizon Hobby Team demonstrated the Hangar 9 60cc Giant Scale Corsairs (2 powered by Zenoah G62's and (1) by a Saito FG-84R3 radial 4-stroke) as well as the new 30cc Spitfire (powered by Evolution 33 cc gas engines) ARF's several times a day. There was some exceptional flying as each tried to outfly the other by threading the plane between the trees on the far side of the field.

The event ended Saturday with the 4pm Pilots Drawings. This year Steve Meyer won the grand prize of any Balsa USA Kit! Steve chose a design that would fit in his current mini-van so he picked the new Sopwith Camel kit! We hope to see it fly for FDL-2015!

Mitsubishi J2M2 Raiden (Thunderbolt)

by Conrad Naegele

The August Mystery Plane was the Japanese Mitsubishi J2M2 Raiden.

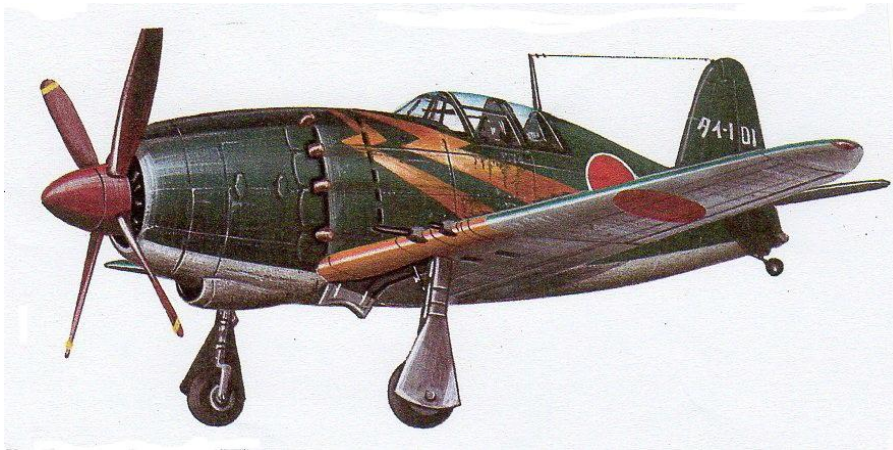

The Japanese Raiden was a radical change in the single-seat fighter concept. For the first time maneuverability became secondary to speed and climb. The Raiden was designed purely for the interceptor role. Designing was begun in 1940 by Jiro Horikoshi, who was responsible for the immortal A6M Zero.

Jiro used a laminar flow wing, plus rather unusual 'combat flaps' that increased lift, momentarily. The prototype flew March 20, 1942. Flight testing revealed a lot of problems, poor vision, and the gear could not be retracted above 100 mph! A more powerful engine was installed, a new canopy followed, along with water ingestion. There followed a series of low level crashes. One pilot managed to land and then it was discovered that the retractable tail wheel shock strut was pressing against the elevator torque tube and control wires, jamming the control stick forward. Design changes continued and dual turbo-chargers were added. It was now the J2M5.

The time to climb was improved to 6 minutes to 19,685 feet. Now the J2M7 was put into production, just about the time the B-29's were raiding the mainland. The Raiden was deadly for the 29's, as it had a service ceiling of 38,000 feet! 3,600 planes were planned, but only 500 were produced before the end of the war.

The Raiden used a Mitsubishi Kasei 14-cylinder radial engine developing 1,820 horsepower. It had a wingspan of 35 feet 5 inches, a gross weight of 8,699 pounds and a speed of 371 mph. For armament it carried four 20mm cannon plus two 66 pound bombs. J

TCRC Membership Report

by Bernie Gaub
Membership Director

The current 2014 TCRC membership count is now at 121. Since records were kept from 1957 until now, this is the highest membership total ever.

Year-to-date membership activity (not including renewals) is as follows:

Returning Members:

Michael R Danielson, who resides at 8401 73rd Ave N (Brooklyn Park, MN). His phone number is 612-385-1429 and his email address is mike@eidecom.com. He is rejoining TCRC after last being a member in 2004. He was with TCRC 7 years at that time. Michael has over 20 years of RC flying experience and is interested in being an instructor. He has a number of aircraft and is anxious to fly again at TCRC.

Charles E Eide, who also resides at 8401 73rd Ave N (Brooklyn Park, MN), is rejoining TCRC after last being a member in 2003. He was with TCRC 5 years at that time. His phone number is 612-387-0248 and his email address is Charles@eidecom.com. Charles has over 20 years of RC flying experience and is also interested in being an instructor. He has a number of aircraft and is anxious to fly again at TCRC.

Please welcome Michael and Charles back to our club when you see them at the field or at any of our monthly meetings. J



BIG SKY HOBBY™
Great products, expert advice.

Open Monday thru Saturday, 10 am - 6 pm
Have Special Orders or Questions?
Contact: Jeremy@BigSkyHobby.com

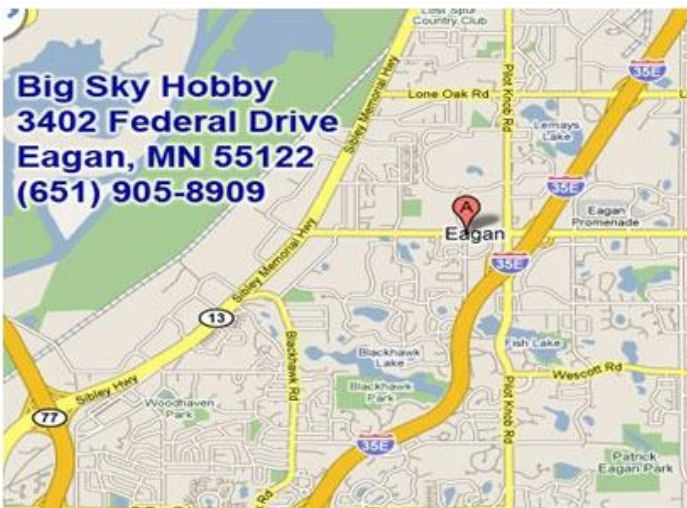

Big Sky Hobby
3402 Federal Drive
Eagan, MN 55122
(651) 905-8909

J J J
 Visit Your
 Local
 Hobby Shop
J J J



HOBBY WAREHOUSE

7144 Chicago Ave S
Richfield, MN 55423
612-861-5587

Specializing in "AIR" RC Hobbies

MyHobbyWarehouse.com
hobbywarehouse2@aol.com

Hours: Mon-Fri 10:00-7:00
Sat 10:00-6:00
Closed major holidays

LOWEST PRICES IN TOWN

Thomas Steinmueller



Stop In Today To Find Out 'The TCRC Special Of The Month'

CONTROL FREAKS RC

952-473-0271 2365 W. Wayzata Blvd Long Lake 55356

Wanna know what's going on?

Subscribe to our newsletter and get a weekly update on all the flying events in the Twin Cities.
Sign Up @ www.ControlFreaksRC.com

Plus get free \$20 to spend at Control Freaks

August Raffle Winner



Jim Ronhovde was the lucky winner of the August Raffle.
(Photo by Janice Ronhovde)

At the August TCRC membership meeting, which was held at the Jordan flying site, Jim Ronhovde won the monthly raffle, and claimed the Great Planes Big Stik 40 ARF. The meeting was well attended and most everyone had purchased at least one chance for the raffle.

The prize for the September meeting will be a Flyzone DHC-2 Beaver on floats, so the winner can bring it to the Fall Float Fly at Bush Lake on October 4th.

Come to the next meeting on September 9th and invest \$5 for a chance to win this really neat aircraft. You can buy as many \$5 chances as you like. J

September Mystery Plane

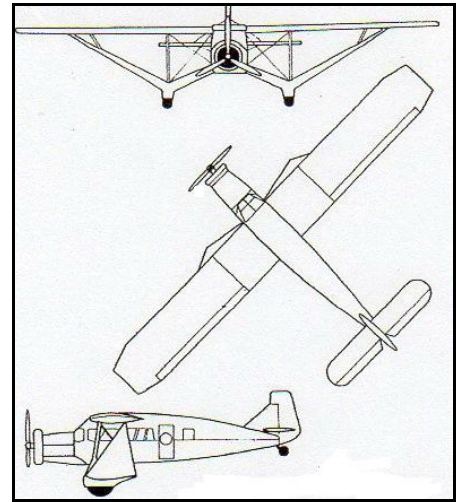

THE TCRC FLARE-OUT Monthly Newsletter



** TWIN CITY RADIO CONTROLLERS INC. **

Purpose: To preserve, encourage, and further develop the hobby of building and flying radio controlled model airplanes.

2014 Officers

President	Bob Breisemeister 612-964-8877
Vice President	Mike Robin 952-440-1331
Secretary	Jim Ronhovde 952-854-9062
Treasurer	Tim Wirtz 952-941-5357

TCRC Flare-Out

Editor	James R. Cook	952-445-5257
Publishers:	Pat Dziuk	952-445-3089
	& Mike Timmerman	952-496-1631

Website: <http://www.tcrconline.com>

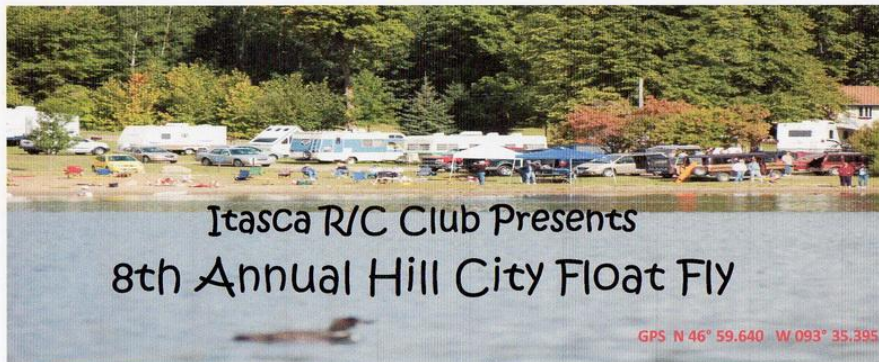

Itasca R/C Club Presents 8th Annual Hill City Float Fly

GPS N 46° 59.640 W 093° 35.395

Date: September 6th & 7th
Time: 8:00 a.m.

Landing Fee--\$20.00 Lunch Included on Saturday
Guest Lunch \$6.00
AMA Pilots Only

Supper will be served Saturday night
For those who stay over
AMA sanctioned event

More information Contact

Rodney Hess
218-244-2827
rchess@scicable.com

Sponsors

Hobby Town; Duluth
Great Planes
Satellite City
Balsa USA
Coles Hardware
RAM

Hill City maintains a great camping site with bath house and hook-ups right at the beach, which is available for a very small city fee.

Prize Drawings, 50/50 Drawings
Spectators, Swappers, and
Campers Welcome